

# Model 3600

## Vacuum Relief Vent

### Side-Mounted Connection

## SECTION I

### I. 3000 SERIES DESIGN AND FUNCTION

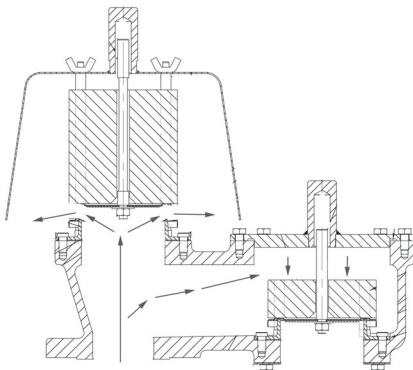
MODEL	P	V	DESCRIPTION
3100	P	V	Vent to Atmosphere
3200	P	V	Vent to Header
3300		V	Top Mounted
3400	P		Vent to Atmosphere
3500	P		Vent to Header
3600		V	Side Mounted
3700	P		Emergency/Manhole Cover

Models 3100 through 3600 Pressure and /or Vacuum Vents are used for the normal venting requirements. Normal venting is defined as venting required because of operational requirements (i.e. filling and emptying the tank) or atmospheric changes. Model 3700 Emergency Relief Vent is used to meet venting required when an abnormal condition, such as an external fire or such as ruptured internal heating coils, exist either outside or inside the tank.

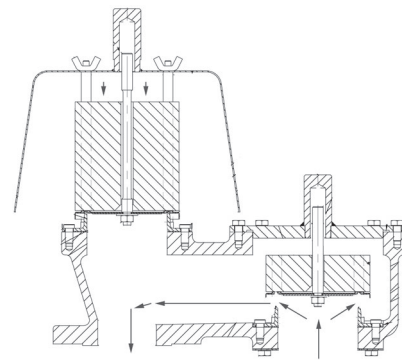
All of these devices are sized in accordance with API Standard 2000. Improperly specified relief vents may result in structural damage to the tank or system and can cause severe personal injury or death.

**Figure 1** illustrates the operation of the Pressure Relief Vent under overpressure conditions. As the tank pressure increases as a result of product being pumped into the tank and/or because of thermal expansion of the product and vapors, the pressure pallet remains closed until the set pressure of the vent is reached. When the tank pressure reaches the pressure setting of the vent, the pressure pallet lifts allowing the tank pressure to bleed off.

**Figure 2** illustrates the operation of the Vacuum Relief Vent under vacuum conditions. As the tank pressure decreases as a result of product being pumped out of the tank and/or because of thermal contraction of the product and vapors, the vacuum pallet remains closed until the set vacuum of the vent is reached. When the tank vacuum reaches the vacuum setting of the vent, the vacuum pallet lifts allowing air to be drawn into the tank.



**Figure 1 - Pressure Relief**



**Figure 2 - Vacuum Relief**

## SECTION II

### II. SAFETY WARNINGS

Tank or system protection is the primary function of the weight loaded Vacuum Relief Vent. It must be selected to meet the total pressure and vacuum flow requirements within the Maximum Allowable Working Pressure and Vacuum of the system on which it is installed. Consult API Standard 2000 for tank protection sizing procedures. Improperly specified relief vents may result in structural damage to the tank or system and can cause severe personal injury or death.

When Pipe-Away relief vents are used, back pressure in the header system will affect the set point of weight loaded vents by the amount of the header pressure. Maximum possible header pressure must be considered when sizing the pressure relief vent.



#### CAUTION

**DO NOT attempt to remove the vent from the tank or process vessel without first bleeding all pressure from the system. ALTERNATIVE MEANS OF VACUUM RELIEF MUST BE PROVIDED WHEN THE VENT IS OUT OF SERVICE.**



#### CAUTION

**DO NOT change vacuum setpoint by adding additional weights to the pallet assembly without consulting Cashco or your VCI representative.**

## SECTION III

### III. INSPECTION AND STORAGE

The vacuum relief vent is carefully packaged to prevent damage or contamination during shipping. Inspect the equipment when it is received and report any damage to the carrier immediately. The vent should be stored with all the protective flange covers

in place. Make sure that any loading weights that might have been shipped separately, to protect the vent during shipping, are accounted for and stored with the vent. These weights, when required, will be installed during installation. See Section IV.

## SECTION IV

### IV. INSTALLATION



#### WARNING

**The vent must be installed in a vertical position as shown in Figure 1. The tank nozzle on which the vent is mounted should have the same nominal diameter as the venting device. It is recommended that the tank nozzle flange face be within 1 degree of horizontal for best performance of the venting device.**

The 3000 Series Vents are designed to mate to a flange. Torque guidelines are provided in Table 1. The Vents are **NOT** rated for full flange pressure and do not require high bolting torque.

Before installing any 3000 Series Vent, remove all packing materials from inside and outside the vent. If loading weights were shipped separate from the vent, make sure to install the weights.

Install heaviest weight first, followed by lighter weights. If weight package includes a round weight, the round weight must be installed first. Tighten cover dome cap screws to 15 ft.-lbs.

**NOTE:** Wipe down the Seat Ring and Diaphragm when all the packing materials have been removed.

Inspect the gasket seating surface of the tank nozzle flange. It must be clean, free of scratches, corrosion, tool marks and flat.

FRP and Aluminum vents are furnished with flat faced flanges. It is recommended that they be installed on mating flat face flanges with a full faced gasket. If the flat face of the vent is sealing against a raised face steel flange, a spacer or filler ring must be used to fill the annular space of the raised face steel flange.

Make sure the gasket is suitable for the application.



### WARNING

Minimum clearance between tank roof and vacuum inlet port must be at least equal to the vents' nominal flange bore. Tank nozzle bore must be greater than or equal to vent inlet flange bore. Inlet and outlet piping loads must be supported by appropriate structural supports, NOT by the vent body.

Fiberglass flanges 2 inch to 12 inch require the use of a full-face 150 lb. gasket. For full face gaskets, we recommend the use of a 1/8-inch Gortex gasket.

Center the gasket within the bolt circle of the tank flange, align the bolt holes and carefully set the vent on the flange nozzle.

**NOTE:** At installation, the vent valve should be carefully lifted into position using the lifting brackets (2) on the body.



### CAUTION

The lifting brackets should only be used for lifting the vent valve into place and should NOT be used for any other purpose.

All stud threads must be lubricated to obtain proper torque results. A washer should be used under each stud nut.

Install the studs, washers and nuts and tighten nuts hand tight. Check proper alignment of flange faces. Misalignment of flange faces will cause bending stresses at the flange and flange joint and damage may result. Correct any misalignment prior to applying torque to nuts.

All nuts must be tightened in proper sequence and equal increments. Proceed through the tightening sequence until the recommended torque is attained.

Recheck the torque on each bolt in the same sequence as bolts previously tightened may have relaxed through the torque sequence.

**TABLE 1**  
Torque Requirements Are Dependant  
On Gasket Material.  
Bolt Torque Specifications -  
ASME #150 Flange Connections

MOUNTING FLANGE SIZE	BOLT TORQUE - Ft. lbs.	NUMBER BOLTS
2"	47	4
3"		4
4"		8
6"	83	8
8"		8
10"	134	12
12"		12

**Bolt Torque for FRP Flanges Drilled to ASME #150 Flange Connections**

MOUNTING FLANGE SIZE	BOLT TORQUE - Ft. lbs.	NUMBER BOLTS
	FLAT FACE	
2"	20	4
3"	20	4
4"	20	8
6"	30	8
8"	30	8
10"	30	12
12"	30	12

## SECTION V

### V. MAINTENANCE

Tank or system protection is the primary function of the weight loaded Vacuum Relief Vent. As a safety device, it is very important that maintenance/inspection be done on a regular interval. Maintenance should only be done by a qualified technician. Valve Concepts recommends that all service be performed at the factory or a factory authorized repair center. For information on repair centers in your area, please contact factory.

**Maintenance procedures hereinafter are based upon removal of the relief vent unit from the tank where installed.**

Owner should refer to Owner's procedures for removal, handling and cleaning of nonreusable parts, i.e. gaskets, suitable solvents, etc.

**To Dis-assemble:** Remove cap screws (10), cover (8) and the TFE tape / rope seal (34).

Inspect cover for corrosion, damage, or product build up. Clean with a suitable solvent, replace as necessary.

**NOTE:** During re-assembly, install new TFE tape / rope (34).

Remove pallet assembly, including any loading weights (28) that may be on the pallet (26).

Clean and inspect pallet assembly. Inspect the diaphragms (25) and replace if necessary.

**To Replace Diaphragm:** Secure stem assembly (30) in a soft-jawed vise with short, threaded end up. Remove washer and nut (14).

Lift up to remove diaphragm retainer (24) and diaphragm (25). Clean stem assembly and diaphragm retainer with a suitable solvent, replace as necessary. **NOTE:** Before re-assembly, apply TFE paste to threads of the stem and around center hole on the pallet (26).

Install new diaphragm (25). Re-install diaphragm retainer (24) and washer, secure nut (14) tight on stem.

Inspect and clean seat ring (16). **NOTE:** FRP seat surfaces are integral inside the body. Check seat surface for any nicks, corrosion, pitting or product

build up. Seat surface must be clean and smooth for vent to perform properly.

**To Remove Seat Ring:** Make a match mark between the flange (1) and the upper body (13). Rotate cap screws (15) CCW and remove. Remove guides (29). (Use the slot on top of the guides and rotate CCW to remove.) Mark the location of each guide on the seat ring (16) flange for reference at re-assembly.



#### CAUTION

**The pipeaway body (13) is no longer fastened securely to the flange (1) and could fall and cause severe personal injury and material damage.**

Lift up to remove seat ring (16) and TFE tape / rope seal (34.1). Inspect guides (29) and inside of the body cavity for any corrosion or product build up. Clean all parts as necessary.

**To Remove Pipeaway Tape Seals:** Separate pipeaway upper body (13) from flange (1). Remove TFE tape seals (34.1 & 34.2) and clean sealing surface of both parts. Place new TFE tape seals (34.1 & 34.2) in grooves on flange (1) face. See Figure 8.

Using match marks align upper body with flange and lower pipeaway body on flange, resting on tape seals.

Place new seat ring TFE tape seal (34.1) in groove in upper body (13). See Figure 8

Using match marks align seat ring (16) with body and re-position seat ring back in body, resting on tape seal.

Re-install pallet guides (29) around the seat ring as previously marked. Install cap screws (15) - apply 15 ft.-lbs. (20.3 Nm) torque to tighten.

Place pallet stem assembly on seat ring (16).



## WARNING

When assembling the vent, ensure that the stem is straight and fits into the guide in the cover. If the stem is cocked at an angle, pallet lift may be completely blocked. This could result in an increase in vacuum pressure in the tank and cause a tank failure, severe personal injury and material damage.

Carefully install loading weights on the pallet stem assembly. Exercise care so as not to damage the pallet diaphragm and seat surface.

**NOTE:** When installing the cover (8), ensure the pressure stem assembly (30) is inserted in the cover guide.

Place a new piece of TFE tape / rope seal (34.0) on the face of the body cover flange. See Figure 8. Place cover (8) over stem of pallet assembly, align bolt holes with the body (1) and install cap screws (10). Using a star crossing pattern, tighten nuts to 15 ft. lbs. (20.3 Nm).

**To Remove Flame Screen:** Rotate cap screws (42) CCW and remove cap screws and ring (41). Inspect and clean screen (40) and reinstall to body (1). See Figure 5.

## SECTION VI

### VI. TEST PROCEDURE

**To Calculate Weight of Pallet Assembly:**

Table 2 shows the pallet weight per unit of pressure or vacuum setting. The total pallet assembly weight is determined by multiplying the desired set point (in the appropriate units) by the incremental weight per unit listed in Table 2.

For Example:

4" Model 3604 CS - if the desired setting is 5 oz/in<sup>2</sup>

Table 2 shows that for a 4" vent, the pallet would weigh 2.05 lb per oz/in<sup>2</sup>

So the pallet assembly for a 5 oz/in<sup>2</sup> setting would weigh: 2.05 lbs/oz/in<sup>2</sup> x 5.0 oz./in<sup>2</sup> - 10.25 lbs

Valve Concepts allows a deviation from this theoretical weight of ± 3.0%.

**To Determine Diaphragm/Seat Leakage:**

After both pallets' weight has been determined and verified for the required setting, reassemble the vent and mount on a Tank Vent Test Stand and slowly raise the pressure at the flow rate per API Standard 2000.

**ACCEPTANCE CRITERIA:**

The pressure gauge shall maintain a pressure equal to or greater than 75% of set pressure for a one minute period while the specified flow rate is maintained. Note: Valve Concepts acceptance criteria meets or exceeds the requirements of API. API 2521 states that if the rate of leakage does not exceed ½ SCFH for 6 inch size and smaller, 5 SCFH for 8 inch to 16 inch, or 20 SCFH for larger than 16 inch, at 75% of set point, then a vent is considered satisfactory for all practical purposes.

A test report should be completed for each vent. The report should indicate the total pallet weight and the pressure achieved at the Test Flow Rate for both pressure and vacuum. Other general information such as serial number, model number, material of construction, set pressure and vacuum, etc. should be included in the report.

The test report should be kept with the Valve Maintenance Records.

**TABLE 2  
Nominal Pallet Assembly Weight Per Unit of Pressure lbs (kg)**

SET Point Units	VALVE SIZE							
	2" VTA	2" PV	3"	4"	6"	8"	10"	12"
	Lb (kg)	Lb (kg)	Lb (kg)	Lb (kg)	Lb (kg)	Lb (kg)	Lb (kg)	Lb (kg)
1.0 oz/in <sup>2</sup>	0.25 (0.11)	0.55 (0.25)	0.93 (0.42)	2.05 (0.93)	3.50 (1.59)	5.45 (2.47)	7.71 (3.50)	9.17 (4.16)
1.0 in WC	0.15 (0.07)	0.32 (0.14)	0.54 (0.24)	1.18 (0.53)	2.03 (0.92)	3.15 (1.43)	4.46 (2.02)	5.30 (2.40)
1.0 mbar	0.13 (0.06)	0.13 (0.06)	0.22 (0.10)	0.48 (0.22)	0.81 (0.37)	1.26 (0.57)	1.79 (0.81)	2.13 (0.97)

**TABLE 3  
Maximum Setting in oz/in<sup>2</sup> Vs. Diaphragm mil**

Line Size	10 mil	20 mil	30 mil	40 mil
2" VTA	7.00	34.00	40.00	n/a
2" P/V	4.50	23.50	33.00	40.00
3" P/V	3.50	18.00	25.00	40.00
4" P/V	2.25	12.00	17.00	40.00
6" P/V	1.75	9.25	13.25	40.00
8" P/V	1.75	7.50	10.50	40.00
10" P/V	1.25	6.25	8.75	40.00
12" P/V	1.00	5.75	8.00	40.00

## SECTION VII

### VII. ORDERING INFORMATION

#### NEW REPLACEMENT UNIT vs PARTS "KIT" FOR FIELD REPAIR

To obtain a quotation or place an order, please retrieve the Serial Number and Product Code that was stamped on the metal name plate and attached to the unit. This information can also be found on the Bill of Material (BOM), a parts list that was provided when unit was originally shipped. (Serial Number typically 6 digits).

#### **NEW REPLACEMENT UNIT:**

Contact your local Cashco Sales Representative with the Serial Number, Product code and the vacuum setting. With this information they can provide a quotation for a new unit including a complete description, price and availability.

#### **PARTS "KIT" for FIELD REPAIR:**

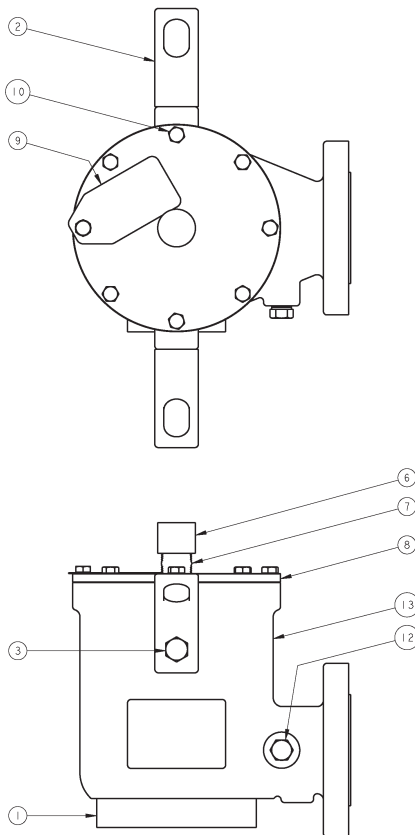
Contact your local Cashco Sales Representative with the Serial Number and Product code. Identify the parts and the quantity required to repair the unit from the "BOM" sheet that was provided when unit was originally shipped.

**NOTE:** If the "BOM" is not available, refer to the cross-sectional drawings included in this manual for part identification and selection.

A Local Sales Representative will provide quotation for appropriate Kit Number, Price and Availability.

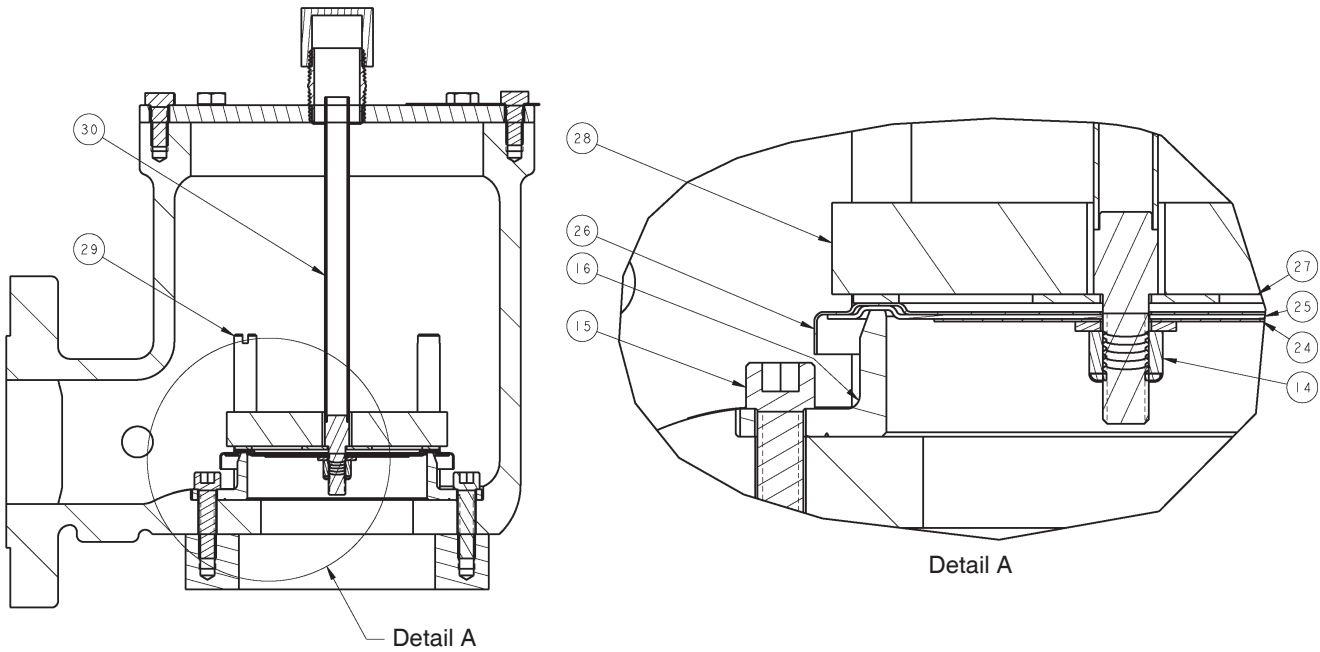
**⚠ CAUTION**

**Do not attempt to alter the original construction of any unit without assistance and approval from the factory. All proposed changes will require a new name plate with appropriate ratings and new product code to accommodate the recommended part(s) changes.**



**Figure 3 - Side View with Lifting brackets**

**Figure 4 - Standard Vent  
Aluminum, Carbon Steel, Stainless Steel**



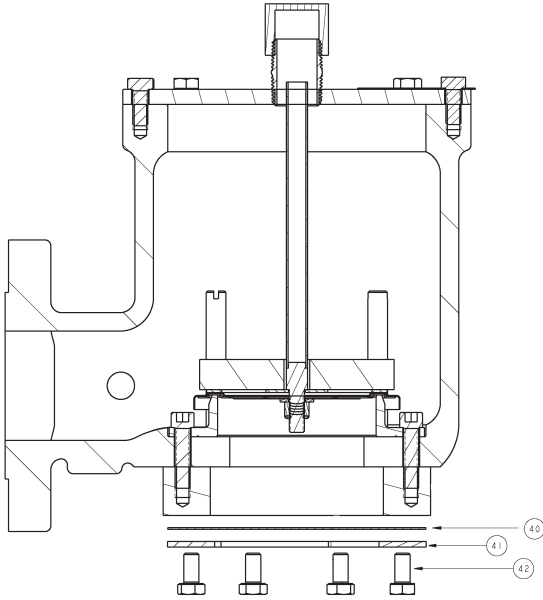
ITEM NO.	DESCRIPTION
1	Flange
2	Lift Brackets
3	Cap Screws
6	Cap
7	Nipple
8	Cover
9	Name Plate
10	Cap Screws
12	Pipe Plug
13	Upper Body
14	Nut *

ITEM NO.	DESCRIPTION
15	Socket Cap Screw
16	Seat Ring
24	Diaphragm Retainer
25	Pallet Diaphragm ‡
26	Pallet
27	Stiffener Plate
28	Pallet Weights
29	Pallet Guide
30	Stem Assy
‡	Recommended Spare Part

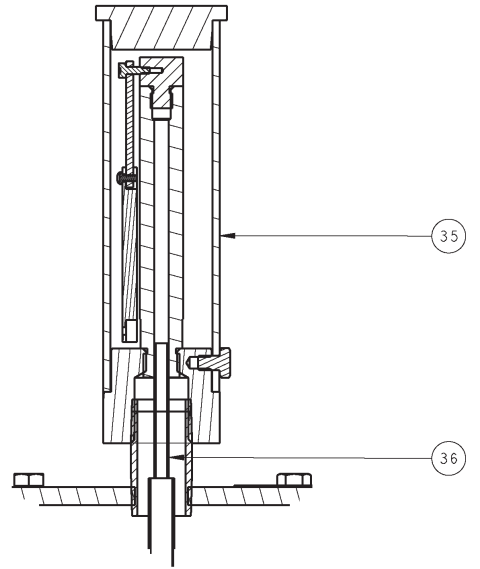
\* Early Models included a lock washer, plain washer and a cotter pin.



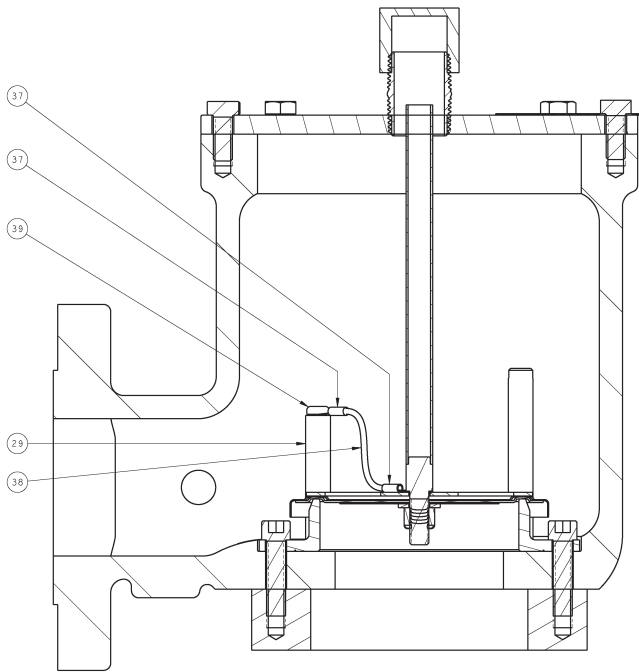
**Figure 5 - Bug / Flame Screen**



**Figure 6 - Indicator**

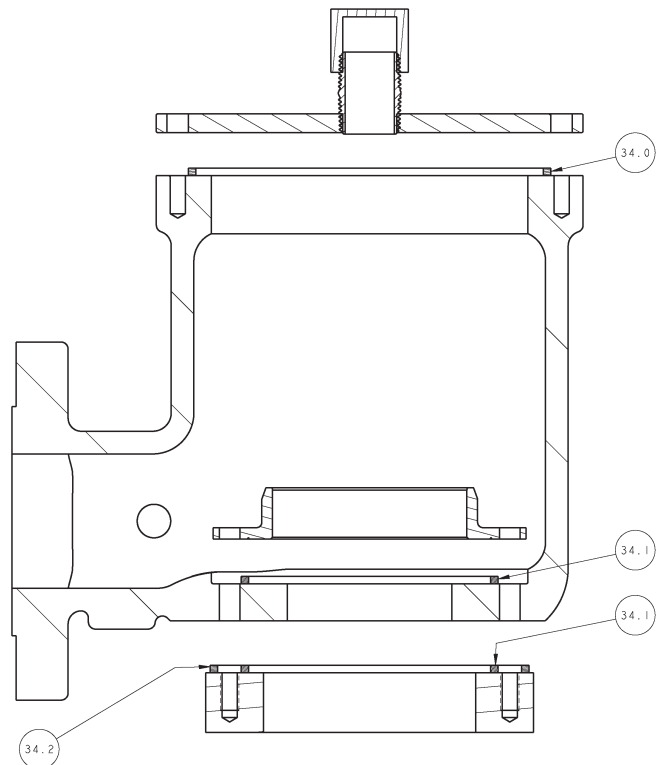


**Figure 7 - Atex Cable Connection**



- | ITEM NO. | DESCRIPTION        |
|----------|--------------------|
| 29       | Pallet Guide       |
| 35       | Indicator Housing  |
| 36       | Indicator          |
| 37       | Cable Connector    |
| 38       | Cable - ATEX       |
| 39       | Cap Screw          |
| 40       | Flame / Bug Screen |
| 41       | Flame Screen Ring  |
| 42       | Cap Screws         |

**Figure 8 - Joint Tape Application**



Size	TFE TAPE LENGTH		
	Item 34.0	Item 34.1 *	Item 34.2
2"	23"	17"	20"
3"	25"	20"	22"
4"	33"	28"	26"
6"	38"	34"	32"
8"	38"	34"	32"
10"	46"	41"	39"
12"	56"	47"	47"
14"	58"	51"	55"

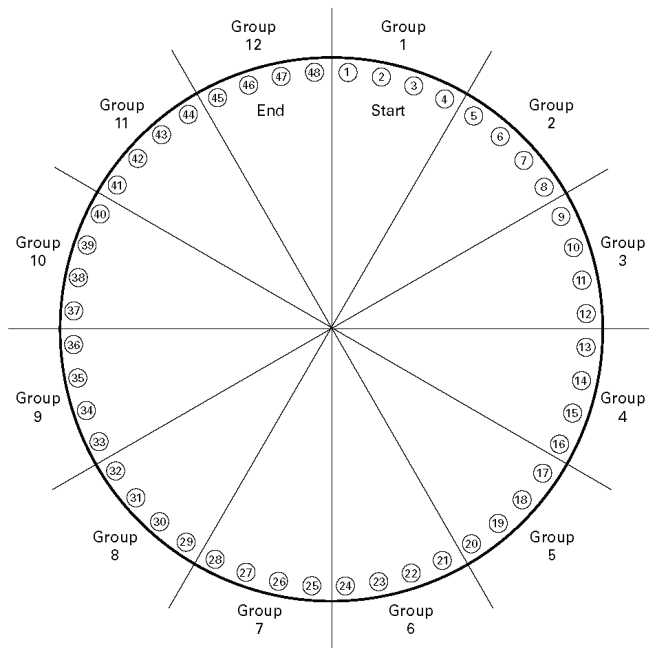
\* Quantity 2 per unit.

# ADDENDUM - A

## TIGHTENING SEQUENCE FOR FLANGE BOLTING

GUIDELINES FOR BOLTED FLANGE JOINT ASSEMBLY ACCORDING TO ASME PCC-1 SPECS

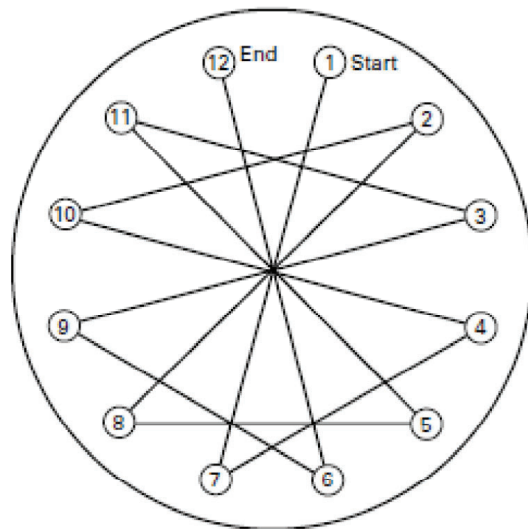
STEP	LOADING
Install	Hand tighten. Check flange gap around circumference for uniformity. If the gap is not reasonably uniform, make the appropriate adjustments by selective tightening before proceeding.
Round 1	Tighten to 20% to 30% of target torque. Check flange gap around circumference for uniformity. If the gap is not reasonably uniform, make the appropriate adjustments by selective tightening before proceeding.
Round 2	Tighten to 50% to 70% of target torque. Check flange gap around circumference for uniformity. If the gap is not reasonably uniform, make the appropriate adjustments by selective tightening before proceeding.
Round 3	Tighten to 100% of target torque. Check flange gap around circumference for uniformity. If the gap is not reasonably uniform, make the appropriate adjustments by selective tightening.



Group	Bolts
1	1-2-3-4
2	5-6-7-8
3	9-10-11-12
4	13-14-15-16
5	17-18-19-20
6	21-22-23-24
7	25-26-27-28
8	29-30-31-32
9	33-34-35-36
10	37-38-39-40
11	41-42-43-44
12	45-46-47-48

Tightening sequence for 12 Groups:  
 1-7-4-10 ↙  
 2-8-5-11 ↙  
 3-9-6-12

The 12-group sequence is the same as a 12-bolt sequence



1-7-4-10 → 2-8-5-11 → 3-9-6-12

## RECOMMENDATIONS FOR PROPER GASKET INSTALLATION

Gasket seating surfaces for tank nozzle flange must be clean, free of scratches, corrosion, tool marks and flat. Use either a full faced or ring gasket for steel and stainless steel raised face flanges.

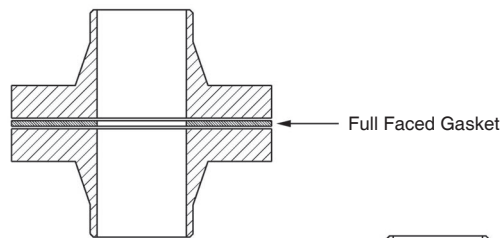
FRP and Aluminum vents are furnished with flat faced flanges. It is recommended that they be installed on mating flat face flanges with a full faced gasket. If the flat face of the vent is sealing against a raised face steel flange, a spacer or filler ring must be used to fill the annular space of the raised face steel flange.

Refer to Gasket Dimension Table.

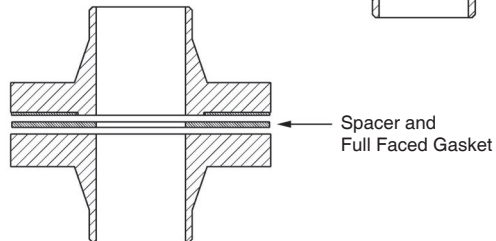
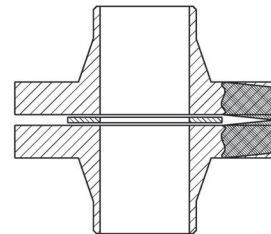
Ensure that the gasket material is suitable for the service. Make sure that the gasket is compressed evenly and the flanges are not distorted. Utilizing proper torquing techniques will ensure a tight seal and prevent leakage around the gasket. See preceding page.

**NOTE:** *Incorrect positioning and/or selection of gasket(s) between the flanges will cause bending stresses at the flange that may damage the flange joint as bolting is tightened. This is more likely to occur with aluminum or cast iron materials.*

Correct Installation



Incorrect Installation



Correct Installation

The contents of this publication are presented for informational purposes only, and while every effort has been made to ensure their accuracy, they are not to be construed as warranties or guarantees, express or implied, regarding the products or services described herein or their use or applicability. We reserve the right to modify or improve the designs or specifications of such product at any time without notice. Cashco does not assume responsibility for the selection, use or maintenance of any product. Responsibility for proper selection, use and maintenance of any Cashco product remains solely with the purchaser.



IOM ADDENDUM:

ATEX DIRECTIVE 2014/34/EU and THE EQUIPMENT AND PROTECTIVE SYSTEMS INTENDED FOR USE IN POTENTIALLY EXPLOSIVE ATMOSPHERES REGULATIONS 2016

Cashco declares that the products listed in the table below has been found to comply with the Essential Health and Safety Requirements relating to the design and construction of products intended for use in potentially explosive atmospheres given in Annex II of the ATEX Directive 2014/34/EU and given in Schedule 1 of The Equipment and Protective Systems Intended for Use in Potentially Explosive Atmospheres Regulations 2016. Compliance with the Essential Health and Safety Requirements has been assured by compliance with EN ISO 80079-36:2016 and EN ISO 80079-37:2016. The product will be marked as follows:



The 'X' placed after the technical file number indicates that the product is subject to specific conditions of use as follows:

1. The maximum surface temperature depends entirely on the operating conditions and not the equipment itself. The combination of the maximum ambient and the maximum process medium temperature shall be used to determine the maximum surface temperature and corresponding temperature classification, considering the safety margins described prescribed in EN ISO 80079-36:2016, Clause 8.2. Additionally, the system designer and users must take precautions to prevent rapid system pressurization which may raise the surface temperature of system components and tubing due to adiabatic compression of the system gas. Furthermore, the Joule-Thomson effect may cause process gases to rise in temperature as they expand going through a regulator. This could raise the external surface temperature of the regulator body and the downstream piping creating a potential source of ignition. Whether the Joule-Thomson effect leads to heating or cooling of the process gas depends on the process gas and the inlet and outlet pressures. The system designer is responsible for determining whether the process gas temperature may raise under any operating conditions.
2. Where the process medium is a liquid or semi-solid material with a surface resistance in excess of  $1G\Omega$ , special precautions shall be taken to ensure the process does not generate electrostatic discharge.
3. Special consideration shall be made regarding the filtration of the process medium if there is a potential for the process medium to contain solid particles. Where particles are present, the process flow shall be  $<1\text{m/s}$  ( $<3.3\text{ft/s}$ ) in order to prevent friction between the process medium and internal surfaces.
4. Effective earthing (grounding) of the product shall be ensured during installation.
5. The valve body/housing shall be regularly cleaned to prevent build up of dust deposits.
6. Regulators must be ordered with the non-relieving option (instead of the self-relieving option) if the process gas they are to be used with is hazardous (flammable, toxic, etc.). The self-relieving option vents process gas through the regulator cap directly into the atmosphere while the non-relieving option does not. Using regulators with the self-relieving option in a flammable gas system could create an explosive atmosphere in the vicinity of the regulator.
7. Tied diaphragm regulators with outlet ranges greater than 7 barg (100 psig) should be preset to minimize the risk that improper operation might lead to an outboard leak and a potentially explosive atmosphere.
8. All equipment must only be fitted with manufacturer's original spare parts.
9. Ensure that only non-sparking tools are used, as per EN 1127-1, Annex A.

	PRODUCT
<b>REGULATORS</b>	31-B, 31-N
	1164, 1164(OPT-45)
	1171, 1171(OPT-45), 1171(CRYO)
	2171, 2171(OPT-45), 2171(CRYO), 3171
	1465, 3381, 3381(OPT-45), 3381(OPT-40)
	4381, 4381(OPT-37), 4381(CRYO), 4381(OPT-45), 5381
	MPRV-H, MPRV-L
	PBE, PBE-L, PBE-H
	CA-1, CA-2
	CA1, SA1, CA4, SA4, CA5, SA5
	DA2, DA4, DA5, DA6, DA8
	DA0, DA1, DAP, SAP
	SLR-1, SLR-2, PTR-1
	ALR-1, ULR-1, PGR-1
	BQ, BQ(OPT-45), BQ(CRYO)
	123, 123(CRYO), 123(OPT-45), 123(OPT-46G)
	123-1+6, 123-1+6(OPT-45), 123-1+6(OPT-46G), 123-1+6+S, 123-1+6+S(OPT-40)
	1000HP, 1000HP(OPT-37), 1000HP(OPT-45), 1000HP(OPT-45G), 1000HP(CRYO)
	1000HP-1+6, 1000HP-1+8, 1000LP, 1000LP(OPT-45), 1000LP(OPT-46G)
	6987
	8310HP, 8310HP-1+6, 8310HP-1+8, 8310LP, 8311HP, 8311LP
	345, 345(OPT-45)
	BA1/BL1, PA1/PL1
	C-BPV, C-PRV, C-CS
	D, D(CRYO), D(OPT-37), D(OPT-20), D(OPT-45)
	DL, DL(LCC), DL(OPT-45)
	BR, BR(CRYO)
	HP, HP(LCC), HP(OPT-45), HP(OPT46G), HP-1+6+S(OPT-40), HP-1+6+S
	P1, P2, P3, P4, P5, P7
	B2, B7
	POSR-1, POSR-2
	5200P, 5300P
	135
NW-PL, NW-SO	
CG-PILOT	
FG1	
<b>CONTROL VALVES</b>	RANGER, 987, PREMIER
	964, 521, 988, 988-MB, 989
	2296/2296HF
	SCV-30, SCV-S
<b>TANK BLANKETING</b>	8700, 8910, 8920, 8930, 8940
	2100, 2199
	3100, 3200, 3300, 3400, 3500, 3600, 3700
	1078, 1088, 1100, 1049
	5100, 5200, 5400, 5500
	4100, 4200, 4300, 4400, 4500, 4600
<b>MISC</b>	764P/PD, 764-37, 764T

Cashco  
P.O. Box 6  
Ellsworth, KS 67439-0006  
PH (785) 472-4461  
Fax. # (785) 472-3539  
www.cashco.com  
email: sales@cashco.com  
Printed in U.S.A. 3600-IOM

Cashco GmbH  
Handwerkerstrasse 15  
15366 Hoppegarten, Germany  
PH +49 3342 30968 0  
Fax. No. +49 3342 30968 29  
www.cashco.com  
email: germany@cashco.com

Cashco do Brasil, Ltda.  
Rua Bonifácio Cubas, 389.  
Cep 02731-000 – Vila Albertina - São Paulo - SP  
PH +55 11 99677 7177  
Fax. No.  
www.cashco.com  
email: brazil@cashco.com