



ISO Registered Company

MODEL 8311LP MODEL 8311HP

BACK PRESSURE RELIEF REGULATORS

OVERVIEW

The Models 8311HP and 8311LP are high capacity, self-contained back pressure/relief regulators with a double-seat design. These units are utilized to control inlet (upstream) pressure between 1 and 200 psig (.07-13.8 Barg). Available in two inlet pressure designs; LP - larger diaphragm design for relief pressures up to 39 psig (2.69 Barg), and HP - smaller diaphragm design for relief pressures up to 260 psig (17.93 Barg).

FEATURES

- High Capacity:** The highest capacity back pressure regulators Cashco manufactures due to dual ports.
- High Stability:** Outstanding operation resulting from balanced design which maximizes opposing plug forces, even at very low pressure drops. Diaphragm isolated from fluid velocity effects.
- Heavy Guiding:** Plug is top and bottom guided with hardened stem guides.
- Broad Setpoint Range:** 8311LP: 1-30 psig (.07-2.1 Barg)
8311HP: 10-200 psig (.69 - 13.8 Barg)
- High Pressure Drop Capability:** Up to 260 psig.

APPLICATIONS

Designed for controlling a wide range of fluids including air, inert gases, chemicals, water, fuel oils and steam. See Table 4 for more information.



MODEL 8311HP



LINE SIZES AVAILABLE

1-1/2" (DN40), 2" (DN50), 2-1/2" (DN65), 3" (DN80), 4" (DN100)



END CONNECTIONS

NPT, FLANGED, RAISED FACED, FLAT FACED, 14" FACE TO FACE



COMMON APPLICATIONS

AIR, INERT GASES, CHEMICALS, WATER, FUEL OILS, STEAM



DESIGN PRESSURE

INLET PRESSURE:
LP VARIATION: UP TO 39 psig (2.69 Barg)
HP VARIATION: UP TO 260 psig (17.93 Barg)

CAUTION

THIS IS NOT A SAFETY DEVICE AND MUST NOT BE SUBSTITUTED FOR A CODE APPROVED PRESSURE SAFETY RELIEF VALVE OR RUPTURE DISC.

STANDARD/GENERAL SPECIFICATIONS

Variations: LP- "Low Pressure" variation, larger diaphragm area.
 HP - "High Pressure" variation, smaller diaphragm area.

Painting: Standard: All non-corrosion resistant portions to be painted with corrosion resistant epoxy paint per Cashco Spec #S-1606.

Body Sizes: 1-1/2", 2", 2-1/2", 3" and 4"
 (DN40,50,65,80, and 100)

End Connections: NPT - 1-1/2" & 2" (DN40 & 50) only.
Opt-30: Integral Flanged:
 CI with 125 lb. FF, CS with 150 lb. RF Flanges – all sizes.
 CI with 250 lb. RF, CS with 300 lb. RF Flanges – all sizes.
Opt-34: 14" Face to Face Flange Dim. (CS - Sizes 1-1/2" & 2" only)

Body & Spring Chamber Materials:
 HP - CI/DI, CS/CS
 LP - CI/CI,CS/CS
 CI = Cast Iron
 DI - Ductile Iron
 CS = Cast Carbon Steel

Inlet Pressure: LP Variation - up to 39 psig (2.69 Barg).
 HP Variation - up to 260 psig (17.93 Barg).

Inlet Temperature: -20 to 450°F (-29° to +232°C)

Gaskets: Flat gaskets - Graphite/ NBR,
 TFE/AL - Silicate.
 O-ring - TFE.

Seat Leakage: ANSI B16.104, Class II.

Trim Design: 316 SST, metal or composition seated, balanced, double ported. Eight material combination choices.

Capacities: Up to 100 Cv.

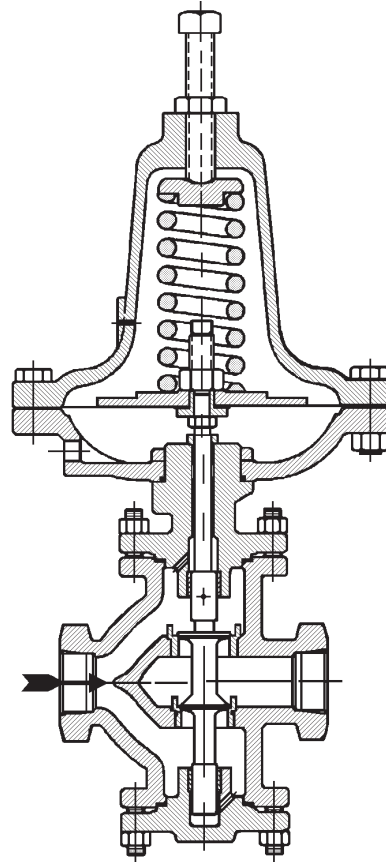

Figure 1: Model 8311HP, metal seated.
 (NOTE: Model 8311LP has larger diaphragm area.)

OPTION SPECIFICATIONS

Option -1: CLOSING CAP. Used to prevent tampering with the set point pressure. Available on all spring chamber materials. Consists of a ductile iron closing cap, a sealing gasket, a sealing lock nut on the adjusting screw, and a 1/4" NPT female tapped spring chamber vent hole.

Option -15: STELLITED SEATS. Stellite seating surfaces on metal seating portions of plug and on both seat rings. See Table 1 for maximum allowable pressure drops.

Option -25: TAPPED VENT. 1/4" NPT (DN8) tapped opening in spring chamber for piping vent to remote location in event of diaphragm failure.

Option -25P: PLASTIC RAIN PROOF BUG VENT. (For Opt-25).

Option -25S: SST RAIN PROOF BUG VENT. (For Opt-25).

Option -30: INTEGRAL FLANGED END CONNECTIONS. Available with 125# FF and 250# RF flanges for cast iron body material or with 150# or 300# RF flanges for cast steel body material.

Option -34: SPECIAL 14" FACE TO FACE DIMENSION FOR FLANGED END CONNECTIONS. CS body material, sizes 1-1/2" & 2" with 150# or 300# RF flanges only. See Opt.-30 for standard face to face dimension.

Option-80: HIGH INLET PRESSURE CONSTRUCTION. Utilized for 130-200 psig (9.0-13.8 Barg) inlet pressure spring range. **ONLY AVAILABLE WITH HP VARIATION.** Special construction includes a diaphragm ring to reduce effective diaphragm area and serve as a travel stop in case of over-pressurization.

Option -56: SPECIAL CLEANING. Cleaned per Cashco Specification #S-1542. Utilize when cleanliness level better than normal is required and unit is NOT FOR OXYGEN SERVICE.

TECHNICAL SPECIFICATIONS

**TABLE 1
MAXIMUM ALLOWABLE PRESSURE DROPS**

Fluid	Maximum Recommended Operating Pressure Drop						Option Number	Trim Designation Number
	Model 8311LP		Model 8311HP					
	All Fluid Qualities		Clean Fluid Industrial Quality		Unclean Fluid Pipeline Quality			
	psid	(Bard)	psid	(Bard)	psid	(Bard)		
Non-Cavitating Liquid	150	(10.3)	200	(13.8)	100	(6.9)	None	All
	150	(10.3)	260	(17.9)	150	(10.3)	Stellited Option-15	
Cavitating Liquids	Consult Factory		Consult Factory		N/R		Stellited	S1 Only Option-15
Gas	200	(13.8)	260	(17.9)	150	(10.3)	None	All
	200	(13.8)	260	(17.9)	260	(17.9)	Stellited Option-15	
Steam	150	(10.3)	150	(10.3)	NR		None	S1, S36R
	200	(13.8)	260	(17.9)	150	(10.3)	Stellited Option-15	

**TABLE 2
DESIGN PRESSURE-TEMPERATURE MATERIAL LIMITS**

MODEL 8311LP								
Material Specifications		End Connection	Inlet			Outlet Diaphragm Design		
Description Abbreviation (Body/Sp.Ch.)	ASTM No.		Pressure		Temperature °F (°C)	Metal	Composition	
			psig	(Barg)		S1, 36, 3R Trim Temp °F (°C)	S5, S7, S7R Trim Temp °F (°C)	S3, S40 Trim Temp °F (°C)
Cast Iron (CI/CI)	A126 Class B	125# Flgd., 250# Flgd., or NPT	39	(2.69)	-20 to +450 (-29 to +232)	-20 to +450 (-29 to +232)	-20 to +400 (-29 to +205)	-20 to +180 (-29 to +83)
Cast Carbon Steel (CS/CS)	A216 Grade WCB	150# Flgd., 300# Flgd., or NPT	39	(2.69)	-20 to +450 (-29 to +232)	-20 to +450 (-29 to +232)	-20 to +400 (-29 to +205)	-20 to +180 (-29 to +83)

**TABLE 3
DESIGN PRESSURE-TEMPERATURE MATERIAL LIMITS**

MODEL 8311HP							
Material Specifications		End Connection	Inlet		Outlet Diaphrag Design		
Description Abbreviation (Body/Sp.Ch.)	ASTM No.		Pressure psig (Barg)	Temperature °F (°C)	Metal	Composition	
					S1, 36, 3R Trim	S5, S7, S7R Trim	S3, S40 Trim
Cast Iron/ Ductile Iron (CI/DI)	A126 Class B/ A395, GR. 60-40-18	125# Flanged	200 (13.8)	-20 to +150 (-29 to +66)	-20 to +150 (-29 to +66)	-20 to +150 (-29 to +66)	-20 to +150 (-29 to +66)
			190 (13.1)	200 (94)	200 (94)	200 (94)	-20 to +180 (-29 to +83)
			175 (12.1)	250 (121)	250 (121)	250 (121)	
			165 (11.4)	300 (149)	300 (149)	300 (149)	
			140 (9.7)	400 (205)	400 (205)	400 (205)	
		125 (8.6)	450 (232)	450 (232)	400 (205)		
		250# Flanged or NPT	260 * (17.9)	-20 to +400 (-29 to +205)	-20 to +450 (-29 to +232)	-20 to +400 (-29 to +205)	-20 to +180 (-29 to +83)
250 * (17.2) & Lower	450 (232)						
Cast Carbon Steel (CS/CS)	A216 Grade WCB	150# Flanged	260 * (17.9)	-20 to +200 (-29 to +94)	-20 to +400 (-29 to +205)	-20 to +400 (-29 to +205)	-20 to +180 (-29 to +83)
			230 * (15.9)	300 (149)			
			200 (13.8)	400 (205)			
			185 (12.8) & Lower	450 (232)	-20 to +450 (-29 to +232)		
		300# Flanged or NPT	260 * (17.9)	-20 to +450 (-29 to +232)	-20 to +450 (-29 to +232)	-20 to +400 (-29 to +205)	-20 to +180 (-29 to +83)

* Max Inlet Pressure for S5 Trim is 200 psig (13.8 barg).

**TABLE 4
APPLICATIONS**

Fluid	Recommended Construction	Trim Designation
		Number
Air or Industrial Gases	Composition Seat & Diaphragm	S3, S7
Chemicals	Metal Seat & Composition Diaphragm	S5, S40
	Metal Seat & Diaphragm	S1
	Composition Seat & Diaphragm	S3
	Composition Seat & Metal Diaphragm	S36, S36R
Hydrocarbon Gas or Liquids	Metal Seat & Composition Diaphragm	S5, S40
	Metal Seat & Diaphragm	S1
	Composition Seat & Diaphragm	S3, S7, SR
Water and Condensate	Metal Seat & Composition Diaphragm	S40
	Metal Seat & Diaphragm	S1
	Composition Seat & Diaphragm	S3
Steam - Saturated or Superheated	Metal Seat & Diaphragm	S1

* In accordance with ASME B31.3 "process piping", do not use Cast Iron Body for hydrocarbon or flammable fluid service with inlet pressures greater than 150 Psig (10.3 Barg) or temperatures greater than 300° F (149° C).

**TABLE 5
STAINLESS STEEL MATERIAL COMBINATIONS**

Part	SST Trim Designation Number		
	Metal Diaphragm		
	S1	S36	S36R
Diaphragm	302 SST	302 SST	302 SST
Plug	316 SST	316 SST	316 SST
Seat Rings	316 SST	316 SST	316 SST
Seat Disc	316 SST ***	TFE	Rulon LR
Stem	316 SST	316 SST	316 SST
Belleville Washer	300 Series SST	300 Series SST	300 Series SST
Stem Guides	Hardened 440C SST	Hardened 440C SST	Hardened 440C SST
Bonnet Plug	**	**	**
Pusher Plate	303 SST	303 SST	303 SST
Pusher Plate Nut	Steel	Steel	Steel
Diaphragm Casing O-Ring	TFE	TFE	TFE
Stem Bushing	303 SST	303 SST	303 SST
Bonnet Nut	Steel	Steel	Steel
Needle Valve	Steel	Steel	Steel
Pipe Nipple	Steel	Steel	Steel

** Same as body material.

*** 316 SST seat disc is integral to the plug.

Part	SST Trim Designation Number				
	Composition Diaphragm				
	S3	S40	S5	S7	S7R
Diaphragm	Neoprene	Neoprene	Fluorocarbon Elastomer	Fluorocarbon Elastomer	Fluorocarbon Elastomer
Plug	316 SST	316 SST	316 SST	316 SST	316 SST
Seat Rings	316 SST	316 SST	316 SST	316 SST	316 SST
Seat Disc	TFE	316 SST ***	316 SST ***	TFE	Rulon LR
Stem	316 SST	316 SST	316 SST	316 SST	316 SST
Belleville Washer	300 Series SST	300 Series SST	300 Series SST	300 Series SST	300 Series SST
Stem Guides	Hardened 440C SST	Hardened 440C SST	Hardened 440C SST	Hardened 440C SST	Hardened 440C SST
Bonnet Plug	**	**	**	**	**
Pusher Plate	303 SST	303 SST	303 SST	303 SST	303 SST
Pusher Plate Nut	Steel	Steel	Steel	Steel	Steel
Diaphragm Casing O-Ring	TFE	TFE	TFE	TFE	TFE
Stem Bushing	303 SST	303 SST	303 SST	303 SST	303 SST
Bonnet Nut	Steel	Steel	Steel	Steel	Steel
Needle Valve	Steel	Steel	Steel	Steel	Steel
Pipe Nipple	Steel	Steel	Steel	Steel	Steel

** Same as body material.

*** 316 SST seat disc are integral to the plug.

**TABLE 6
STEEL RANGE SPRINGS
METAL OR COMPOSITION DIAPHRAGMS
ALL SIZES**

Construction	Range Spring			
	“LP” Variation		“HP” Variation	
	psig	(barg)	psig	(Barg)
Standard	1 - 4 *	(.07-.28)	10 - 40	(.69-2.8)
	3 - 10	(.21-.69)	30 - 100	(2.1-6.9)
	8 - 30	(.55-2.1)	75 - 145	(5.2-10.0)
Option-80	N/A		130 - 200	(9.3-13.8)
* Composition Diaphragm Only				

**TABLE 7
PRESSURE LIMITS — SAFETY RELIEF VALVE
SIZING & SETPOINT**

Variation	Range Spring		Diaphragm Material	*Emergency Over-Pressure (psig)	Maximum Cv With Valve Plug Wide Open				
	psig	(Barg)			Body Size				
					1-1/2" (DN40)	2" (DN50)	2-1/2" (DN65)	3" (DN80)	4" (DN100)
LP	1 - 4	(.07 - .28)	All	1.5 x UVRS*	27	40	55	78	100
	3 - 10	(.21 - .69)							
	8 - 30	(.55 - 2.1)							
HP	10 - 40	(.69 - 2.8)	All	1.5 x UVRS*	27	40	55	78	100
	30 - 100	(2.1 - 6.9)							
	75 - 145	(5.2 - 10.0)							
	130 - 200	(9.3 - 13.8)							

* UVRS = “Upper Value of Range Spring”; i.e. 130-200 psig range spring, value would be 200 psig. Emergency over-pressure quantity must include the pressure build of the selected safety relief valve. DO NOT EXCEED VALUES IN TABLES 2 or 3.

TABLE 8
Model 8311 - "LP VARIATION"
CAPACITY TABLES - Cv — METAL DIAPHRAGM

Set Point (Inlet Pressure, P ₁) (psig)	1-1/2" (DN40) Body			2" (DN50) Body			2-1/2" (DN65) Body			3" (DN80) Body			4" (DN100) Body		
	% Build			% Build			% Build			% Build			% Build		
	10%	20%	30%	10%	20%	30%	10%	20%	30%	10%	20%	30%	10%	20%	30%
5	8.5	15.1	22.5	10.2	19.7	29.9	12.0	22.9	37.5	13.9	26.1	43.1	19.0	36.1	59.8
10 ¹	2.9	5.6	10.0	3.3	6.7	12.0	3.9	7.5	13.2	4.6	8.7	16.0	6.3	12.0	21.7
15	4.2	8.2	12.5	4.8	10.0	16.0	5.5	11.5	18.0	6.8	13.2	21.0	8.1	17.9	28.5
20	6.1	11.5	16.1	7.1	14.1	21.9	8.1	16.5	25.5	9.5	19.0	29.0	13.1	26.4	40.7
25	8.1	14.7	21.7	9.8	18.7	30.1	11.6	22.0	36.0	13.2	25.0	42.4	18.0	30.0	57.5
30	10.9	18.2	23.5	13.2	25.1	32.6	15.5	29.2	41.0	17.9	33.5	46.8	24.5	45.9	65.0

¹ Utilizes 8-30 psig range spring.

TABLE 9
Model 8311 - "LP VARIATION"
CAPACITY TABLES - Cv — COMPOSITION DIAPHRAGM

Set Point (Inlet Pressure, P ₁) (psig)	1-1/2" (DN40) Body			2" (DN50) Body			2-1/2" (DN65) Body			3" (DN80) Body			4" (DN100) Body		
	% Build			% Build			% Build			% Build			% Build		
	10%	20%	30%	10%	20%	30%	10%	20%	30%	10%	20%	30%	10%	20%	30%
2	16.8	25.7	26.2	22.0	35.9	39.3	25.3	46.2	52.8	29.0	58.4	73.2	40.5	81.2	99.0
5	14.0	23.6	26.2	18.0	32.9	38.0	21.1	41.2	50.0	24.0	47.7	67.0	33.1	66.5	94.4
10 ²	5.5	10.8	15.5	6.3	13.0	20.0	7.8	15.3	22.7	8.8	27.4	26.4	12.2	23.9	36.5
15	7.5	14.0	20.0	8.9	18.0	37.3	10.5	21.2	32.3	12.2	24.2	36.8	16.9	33.2	50.7
20	10.0	27.8	23.7	12.2	23.8	33.1	13.8	27.8	41.9	16.2	32.2	48.8	22.2	44.3	67.9
25	13.3	22.3	26.2	16.9	31.2	37.2	19.7	37.8	48.3	22.5	43.7	53.7	31.2	60.3	90.5
30	17.5	25.8	26.2	23.5	36.5	39.3	27.2	47.3	53.6	31.7	61.3	75.0	43.3	86.1	99.8

² Utilizes 8-30 psig range spring

TABLE 10
Model 8311 - "HP VARIATION"
CAPACITY TABLES - Cv — METAL DIAPHRAGM

Set Point (Inlet Pressure, P ₁) (psig)	1-1/2" (DN40) Body			2" (DN50) Body			2-1/2" (DN65) Body			3" (DN80) Body			4" (DN100) Body		
	% Build			% Build			% Build			% Build			% Build		
	10%	20%	30%	10%	20%	30%	10%	20%	30%	10%	20%	30%	10%	20%	30%
10	2.0	4.2	7.5	2.6	6.3	9.0	3.0	6.8	10.5	4.0	7.5	12.0	5.0	11.0	16.7
15	3.0	8.0	12.0	4.0	9.2	14.5	5.0	11.2	16.5	6.0	12.5	19.0	8.5	17.5	23.5
25	7.5	14.0	19.0	8.7	18.0	26.5	10.0	21.0	31.3	11.7	23.7	36.5	18.5	32.5	48.0
35	11.5	19.7	25.2	14.0	27.5	35.7	16.5	32.3	45.7	18.7	37.2	55.7	26.5	51.5	78.7
50	6.2	11.7	16.7	7.3	14.8	22.0	8.0	16.8	25.2	9.5	19.0	28.7	13.0	26.8	39.5
75	8.5	15.5	21.0	10.0	20.3	29.0	11.2	23.5	35.0	13.0	27.0	40.5	18.0	36.5	55.7
100	8.7	18.0	21.2	10.5	21.0	29.5	12.0	23.8	36.0	13.7	27.2	41.3	18.7	37.5	56.5
150	11.4	19.5	25.0	13.8	27.1	35.5	16.2	31.9	45.0	18.5	36.3	55.5	25.0	50.7	76.5
200	14.0	23.5	26.0	18.7	33.4	38.5	21.2	41.3	50.2	24.4	48.5	67.5	33.7	67.5	95.0

TABLE 11
Model 8311 - "HP VARIATION"
CAPACITY TABLES - Cv — COMPOSITION DIAPHRAGM

Set Point (Inlet Pressure, P ₁) (psig)	1-1/2" (DN40) Body			2" (DN50) Body			2-1/2" (DN65) Body			3" (DN80) Body			4" (DN100) Body		
	% Build			% Build			% Build			% Build			% Build		
	10%	20%	30%	10%	20%	30%	10%	20%	30%	10%	20%	30%	10%	20%	30%
10	6.0	11.2	16.2	7.0	14.0	21.5	8.0	16.2	24.8	9.2	18.7	28.7	13.0	26.2	39.1
15	7.5	13.8	19.5	9.1	18.7	27.2	11.2	21.2	32.1	12.5	24.1	36.5	17.0	33.5	50.8
25	10.5	19.0	25.0	13.0	26.3	34.8	15.0	31.0	44.3	17.6	35.5	53.5	24.0	48.8	73.7
35	16.0	25.4	26.2	21.4	35.7	39.0	24.5	45.7	52.4	28.1	56.5	72.2	38.8	78.7	98.2
50	10.5	18.7	24.5	13.0	26.1	34.2	15.0	30.0	43.7	17.4	34.8	52.1	24.0	47.5	72.2
75	15.2	24.7	26.2	20.2	34.7	38.7	22.9	43.7	51.2	26.5	52.8	70.0	36.7	72.8	97.5
100	12.1	21.3	26.0	15.7	29.4	36.9	17.7	36.0	47.5	20.4	41.2	61.3	28.0	57.0	86.0
150	17.8	26.2	26.2	24.4	37.0	39.3	28.0	37.9	53.8	32.4	62.5	75.2	44.2	88.5	100.0
200	21.2	26.2	26.2	29.1	38.8	39.5	35.1	51.5	55.0	40.2	70.8	78.0	55.1	97.5	100.0

TABLE 12
MODEL 8311 - "HP VARIATION"
WATER CAPACITY - GPM

S.G. = 1.0 T = 60°F F_L = 0.88

All Sizes - COMPOSITION DIAPHRAGM ONLY

Outlet Pressure (psig)	Set Point Pressure (psig)	1-1/2" (DN40) Body			2" (DN50) Body			2-1/2" (DN65) Body			3" (DN80) Body			4" (DN100) Body		
		% Build			% Build			% Build			% Build			% Build		
		10%	20%	30%	10%	20%	30%	10%	20%	30%	10%	20%	30%	10%	20%	30%
ATM	10	19.9	38.8	58.4	23.2	48.5	77.5	26.5	56.1	89.4	30.5	64.8	103.5	43.1	90.8	141
	15	30.5	58.5	86.1	37	79.3	120.1	45.5	89.9	141.7	50.8	102.2	161.2	69.1	142.1	224.3
	25	55.1	104.1	CAV	68.2	144.1	CAV	78.7	169.8	CAV	92.3	194.4	CAV	125.9	267.3	CAV
	35	CAV	CAV	CAV	CAV	CAV	CAV	CAV	CAV	CAV	CAV	CAV	CAV	CAV	CAV	CAV
5	10	14.7	29.6	45.8	17.1	37	60.8	19.6	42.9	70.1	22.5	49.5	81.2	31.8	69.3	110.6
	15	25.4	49.8	74.3	30.9	67.4	103.6	38	76.4	122.2	42.4	86.9	139	57.6	120.8	193.4
	25	49.8	95	131.1	61.7	131.5	182.5	71.2	155	232.3	83.5	177.5	280.6	113.8	244	386.5
	35	92.6	154.5	CAV	123.9	217.2	CAV	141.8	278	CAV	162.6	343.7	CAV	224.6	478.7	CAV
10	15	19.1	39	60.1	23.2	52.9	83.8	28.6	60	98.9	31.9	68.2	112.5	43.3	94.8	156.6
	25	43.9	85	118.6	54.4	117.6	165.1	62.7	138.6	210.1	73.6	158.8	253.8	100.4	218.2	349.6
	35	85.4	143.7	156.1	114.2	201.9	232.4	130.8	258.5	312.2	150	319.6	430.2	207.1	445.2	585.1
	50	70.4	CAV	CAV	87.2	CAV	CAV	100.6	CAV	CAV	116.7	CAV	CAV	161	CAV	CAV
15	75	CAV	CAV	CAV	CAV	CAV	CAV	CAV	CAV	CAV	CAV	CAV	CAV	CAV	CAV	CAV
	25	37.1	73.6	104.6	46	101.9	145.6	53	120.1	185.3	62.2	137.5	223.8	84.9	189	308.3
	35	77.6	132	144.7	103.7	185.5	215.4	118.8	237.5	289.4	136.2	293.6	398.7	188.1	408.9	542.3
	50	66.4	125.4	CAV	82.2	175.1	CAV	94.9	201.2	CAV	110	233.4	CAV	151.8	318.6	CAV
25	75	124.9	CAV	CAV	166	CAV	CAV	188.1	CAV	CAV	217.7	CAV	CAV	301.5	CAV	CAV
	100	CAV	CAV	CAV	CAV	CAV	CAV	CAV	CAV	CAV	CAV	CAV	CAV	CAV	CAV	CAV
	35	58.8	104.7	118.6	78.6	147.2	176.6	90	188.4	237.3	103.2	233	326.9	142.6	324.5	444.6
	50	57.5	110.6	155	71.2	154.4	216.3	82.2	177.5	276.4	95.3	205.9	329.5	131.5	281	456.6
25	75	115.3	HI VEL	CAV	153.2	279.8	CAV	173.6	352.3	CAV	200.9	425.7	CAV	278.3	586.9	CAV
	100	111.6	CAV	CAV	144.7	CAV	CAV	163.2	CAV	CAV	188.1	CAV	CAV	258.1	CAV	CAV
	150	CAV	CAV	CAV	CAV	CAV	CAV	CAV	CAV	CAV	CAV	CAV	CAV	CAV	CAV	CAV

NOTE: Where "CAV" is indicated within the above capacity tables, the water has reached full cavitation, and flow is choked. Where "HI VEL" is indicated, the flow has reached or exceeded the velocities to the right based on Schedule 40 pipe.

SIZE	MAX. VEL
1-1/2"	25 fps
2"	27 fps
2-1/2"	29 fps
3"	31 fps
4"	35 fps

TABLE 13
MODEL 8311 - "HP VARIATION"
AIR CAPACITY - SCFH
S.G. = 1.0 T = 60°F F_L = 0.88

All Sizes - COMPOSITION DIAPHRAGM ONLY

Outlet Pressure (psig)	Set Point Pressure (psig)	1-1/2" (DN40) Body			2" (DN50) Body			2-1/2" (DN65) Body			3" (DN80) Body			4" (DN100) Body			
		% Build			% Build			% Build			% Build			% Build			
		10%	20%	30%	10%	20%	30%	10%	20%	30%	10%	20%	30%	10%	20%	30%	
ATM	10	4950	9590	14400	5770	11990	19110	6600	13880	22040	7590	16020	25510	10720	22440	34750	
	15	7510	14480	21400	9110	19620	29850	11210	22240	35220	12510	25280	40050	17020	35150	55740	
	25	14220	27260	37880	17610	37740	52730	20320	44480	67120	23840	50940	81060	32510	70020	111660	
	35	27340	46250	50650	36560	65010	75400	41860	83220	101310	48010	102890	139590	66290	143310	189860	
	50	23520	44890	SONIC	29110	62650	87580	33590	72010	111910	38970	83530	133420	53750	114010	184900	
	75	47500	SONIC	SONIC	63120	SONIC	SONIC	71560	SONIC	SONIC	SONIC	82810	177720	SONIC	114680	245040	351690
	100	48530	SONIC	SONIC	62970	SONIC	SONIC	70990	SONIC	SONIC	SONIC	81820	178500	SONIC	112310	246960	SONIC
	150	SONIC	SONIC	SONIC	SONIC	SONIC	SONIC	SONIC	SONIC	SONIC	SONIC	187360	SONIC	SONIC	255600	SONIC	SONIC
	200	SONIC	SONIC	SONIC	SONIC	SONIC	SONIC	SONIC	SONIC	SONIC	SONIC	SONIC	SONIC	SONIC	SONIC	SONIC	SONIC
5	10	4840	9380	14080	5650	11730	18690	6450	13570	21560	7420	15670	24950	10480	21950	33990	
	15	7510	14480	21400	9110	19620	29850	11210	22240	35220	12510	25280	40050	17020	35150	55740	
	25	14220	27260	37880	17610	37740	52730	20320	44480	67120	23840	50940	81060	32510	70020	111660	
	35	27340	46250	50650	36560	65010	75400	41860	83220	101310	48010	102890	139590	66290	143310	189860	
	50	23520	44890	62740	29110	62650	87580	33590	72010	111910	38970	83530	133420	53750	114010	184900	
	75	47500	SONIC	SONIC	63120	116800	SONIC	71560	147090	SONIC	SONIC	82810	177720	252490	114680	245040	351690
	100	48530	SONIC	SONIC	62970	SONIC	SONIC	70990	155970	SONIC	SONIC	81820	178500	SONIC	112310	246960	400260
	150	SONIC	SONIC	SONIC	SONIC	SONIC	SONIC	161920	SONIC	SONIC	SONIC	187360	SONIC	SONIC	255600	SONIC	SONIC
	200	SONIC	SONIC	SONIC	SONIC	SONIC	SONIC	SONIC	SONIC	SONIC	SONIC	SONIC	SONIC	SONIC	416370	SONIC	SONIC
10	15	6680	12890	19050	8110	17470	26570	9980	19800	31360	11140	22510	35660	15150	31290	49630	
	25	14190	27200	37790	17570	37650	52600	20270	44380	66960	23790	50820	80870	32440	69860	111400	
	35	27340	46250	50650	36560	65010	75400	41860	83220	101310	48010	102890	139590	66290	143310	189860	
	50	23520	44890	62740	29110	62650	87580	33590	72010	111910	38970	83530	133420	53750	114010	184900	
	75	47500	83140	94500	63120	116800	139590	71560	147090	184680	82810	177720	252490	114680	245040	351690	
	100	48530	92280	SONIC	62970	127380	SONIC	70990	155970	221070	81820	178500	285300	112310	246960	400260	
	150	SONIC	SONIC	SONIC	141100	SONIC	SONIC	161920	SONIC	SONIC	SONIC	187360	SONIC	SONIC	255600	554500	SONIC
	200	SONIC	SONIC	SONIC	SONIC	SONIC	SONIC	SONIC	SONIC	SONIC	SONIC	303770	SONIC	SONIC	416370	SONIC	SONIC
15	25	13300	25490	35420	16470	35290	49310	19000	41600	62770	22300	47630	75800	30400	65480	104420	
	35	27180	45990	50360	36350	64630	74970	41620	82740	100720	47730	102290	138780	65910	142480	188760	
	50	23520	44890	62740	29110	62650	87580	33590	72010	111910	38970	83530	133420	53750	114010	184900	
	75	47500	83140	94500	63120	116800	139590	71560	147090	184680	82810	177720	252490	114680	245040	351690	
	100	48530	92280	SONIC	62970	127380	171740	70990	155970	221070	81820	178500	285300	112310	246960	400260	
	150	102930	SONIC	SONIC	141100	SONIC	SONIC	161920	237460	SONIC	SONIC	187360	391600	SONIC	255600	554500	674830
	200	SONIC	SONIC	SONIC	SONIC	SONIC	SONIC	265240	SONIC	SONIC	SONIC	303770	SONIC	SONIC	416370	SONIC	SONIC
25	35	23200	39250	42980	31030	55160	63980	35520	70620	85970	40740	87300	118450	56250	121610	161110	
	50	23000	43900	61370	28480	61280	85670	32860	70430	109470	38120	81700	130510	52580	111520	180860	
	75	47500	83140	94500	63120	116800	139590	71560	147090	184680	82810	177720	252490	114680	245040	351690	
	100	48530	92280	121010	62970	127380	171740	70990	155970	221070	81820	178500	285300	112310	246960	400260	
	150	102930	SONIC	SONIC	141100	231830	SONIC	161920	237460	SONIC	SONIC	187360	391600	507470	255600	554500	674830
200	SONIC	SONIC	SONIC	219900	SONIC	SONIC	265240	SONIC	SONIC	SONIC	303770	SONIC	SONIC	416370	799550	884450	

NOTE: Where "SONIC" is indicated within the above capacity tables, outlet velocity with Schedule 40 pipe has reached sonic velocity of 1118 fps. Additional flow cannot be obtained, and pipeline velocity is in excess of customary pipe velocity design limits. Flow will be approximately the last indicated value in the column above "SONIC".

TABLE 14
MODEL 8311 - "HP VARIATION"
STEAM CAPACITY - LBS/HR
S.G. = Actual T = Saturated F_L = 0.88
All Sizes - METAL DIAPHRAGM

Outlet Pressure (psig)	Set Point Pressure (psig)	1-1/2" (DN40) Body			2" (DN50) Body			2-1/2" (DN65) Body			3" (DN80) Body			4" (DN100) Body		
		% Build			% Build			% Build			% Build			% Build		
		10%	20%	30%	10%	20%	30%	10%	20%	30%	10%	20%	30%	10%	20%	30%
ATM	10	77	161	287	100	241	345	115	261	402	153	287	460	192	421	640
	15	144	385	577	192	442	697	240	539	793	288	601	914	409	841	1130
	25	489	912	HI VEL	567	1173	1727	652	1369	2040	762	1545	2379	1206	2118	3128
	35	946	HI VEL	HI VEL	1152	HI VEL	HI VEL	1357	2657	HI VEL	1538	3060	HI VEL	2180	4236	6473
	50	658	HI VEL	HI VEL	774	1570	HI VEL	849	1782	2673	1008	2016	3045	1379	2843	4190
	75	HI VEL	HI VEL	HI VEL	1457	HI VEL	HI VEL	1631	HI VEL	HI VEL	1894	3933	HI VEL	2622	5317	HI VEL
	100	HI VEL	HI VEL	HI VEL	HI VEL	HI VEL	HI VEL	2223	HI VEL	HI VEL	HI VEL	HI VEL	HI VEL	3464	6947	HI VEL
	150	HI VEL	HI VEL	HI VEL	HI VEL	HI VEL	HI VEL	HI VEL	HI VEL	HI VEL	HI VEL	HI VEL	HI VEL	6583	HI VEL	HI VEL
	200	HI VEL	HI VEL	HI VEL	HI VEL	HI VEL	HI VEL	HI VEL	HI VEL	HI VEL	HI VEL	HI VEL	HI VEL	HI VEL	HI VEL	HI VEL
5	10	62	130	232	80	195	278	93	210	324	124	232	371	154	340	516
	15	132	353	530	177	406	640	221	495	729	265	552	839	375	773	1038
	25	477	891	1209	554	1145	1686	636	1336	1991	744	1508	2322	1177	2068	3054
	35	921	HI VEL	HI VEL	1121	2202	HI VEL	1321	2587	HI VEL	1498	2979	4461	2122	4124	6303
	50	658	1241	HI VEL	774	1570	2334	849	1782	2673	1008	2016	3045	1379	2843	4190
	75	1238	HI VEL	HI VEL	1457	HI VEL	HI VEL	1631	3423	HI VEL	1894	3933	HI VEL	2622	5317	8114
	100	HI VEL	HI VEL	HI VEL	1945	HI VEL	HI VEL	2223	HI VEL	HI VEL	2538	5039	HI VEL	3464	6947	HI VEL
	150	HI VEL	HI VEL	HI VEL	HI VEL	HI VEL	HI VEL	HI VEL	HI VEL	HI VEL	4871	HI VEL	HI VEL	6583	HI VEL	HI VEL
	200	HI VEL	HI VEL	HI VEL	HI VEL	HI VEL	HI VEL	HI VEL	HI VEL	HI VEL	HI VEL	HI VEL	HI VEL	HI VEL	HI VEL	HI VEL
10	15	104	278	416	139	319	503	173	389	572	208	434	659	295	607	815
	25	452	843	1145	524	1084	1597	602	1265	1886	705	1428	2199	1115	1958	2892
	35	908	1556	HI VEL	1106	2172	2820	1303	2552	3610	1477	2939	4400	2093	4068	6217
	50	641	1210	1727	755	1531	2275	827	1737	2606	982	1965	2968	1344	2772	4085
	75	1238	HI VEL	HI VEL	1457	2957	HI VEL	1631	3423	HI VEL	1894	3933	5900	2622	5317	8114
	100	1612	HI VEL	HI VEL	1945	HI VEL	HI VEL	2223	4409	HI VEL	2538	5039	HI VEL	3464	6947	10466
	150	HI VEL	HI VEL	HI VEL	HI VEL	HI VEL	HI VEL	4265	HI VEL	HI VEL	4871	HI VEL	HI VEL	6583	HI VEL	HI VEL
	200	HI VEL	HI VEL	HI VEL	HI VEL	HI VEL	HI VEL	HI VEL	HI VEL	HI VEL	HI VEL	HI VEL	HI VEL	11380	HI VEL	HI VEL
15	25	400	747	1014	465	961	1415	534	1121	1671	625	1265	1949	988	1735	2563
	35	873	1496	1913	1063	2088	2711	1253	2452	3470	1420	2824	4229	2012	3910	5975
	50	637	1201	1715	750	1520	2259	821	1725	2588	976	1951	2947	1335	2752	4056
	75	1238	2258	HI VEL	1457	2957	HI VEL	1631	3423	5098	1894	3933	5900	2622	5317	8114
	100	1612	HI VEL	HI VEL	1945	HI VEL	HI VEL	2223	4409	HI VEL	2538	5039	7651	3464	6947	10466
	150	HI VEL	HI VEL	HI VEL	3634	HI VEL	HI VEL	4265	HI VEL	HI VEL	4871	HI VEL	HI VEL	6583	13349	HI VEL
	200	HI VEL	HI VEL	HI VEL	HI VEL	HI VEL	HI VEL	HI VEL	HI VEL	HI VEL	HI VEL	HI VEL	HI VEL	11380	HI VEL	HI VEL
25	35	703	1204	1541	856	1681	2183	1009	1975	2794	1143	2274	3405	1620	3149	4811
	50	601	1135	1620	708	1436	2134	776	1630	2445	922	1843	2784	1261	2600	3832
	75	1201	2191	2968	1413	2869	4099	1583	3321	4947	1837	3816	5724	2544	5159	7872
	100	1612	HI VEL	HI VEL	1945	3890	HI VEL	2223	4409	6669	2538	5039	7651	3464	6947	10466
	150	3002	HI VEL	HI VEL	3634	HI VEL	HI VEL	4265	HI VEL	HI VEL	4871	9558	HI VEL	6583	13349	HI VEL
	200	HI VEL	HI VEL	HI VEL	HI VEL	HI VEL	HI VEL	HI VEL	HI VEL	HI VEL	8239	HI VEL	HI VEL	11380	HI VEL	HI VEL

NOTE: Where "HI VEL" is indicated, the flow has reached or exceeded a velocity of Mach 0.35, an accepted limit for expanded steam on the downstream side. Use of higher velocities normally generate excessive noise levels.

TABLE 15
MODEL 8311 - "LP VARIATION"
WATER CAPACITY - GPM
S.G. = 1.0 T = 60°F F_L = 0.88
All Sizes - Composition Diaphragm Only

Outlet Pressure (psig)	Set Point Pressure (psig)	1-1/2" (DN40) Body			2" (DN50) Body			2-1/2" (DN65) Body			3" (DN80) Body			4" (DN100) Body		
		% Build			% Build			% Build			% Build			% Build		
		10%	20%	30%	10%	20%	30%	10%	20%	30%	10%	20%	30%	10%	20%	30%
ATM	2	24.9	39.8	42.2	32.6	55.6	63.4	37.5	71.6	85.1	43.0	90.5	118.0	60.1	125.8	159.6
	5	32.8	57.8	66.8	42.2	80.6	96.9	49.5	100.9	127.5	56.3	116.8	170.8	77.6	162.9	240.7
	10	18.2	37.4	55.9	20.9	45.0	72.1	25.9	53.0	81.8	29.2	94.9	95.2	40.5	82.8	131.6
	15	30.5	59.4	88.3	36.2	76.4	164.7	42.7	89.9	142.6	49.6	102.7	162.5	68.6	140.9	223.9
	20	46.9	136.2	120.8	57.2	116.6	168.8	64.7	136.2	213.6	76.0	157.7	248.8	104.1	217.0	346.2
	25	69.7	122.1	CAV	88.6	170.9	CAV	103.3	207.0	CAV	118.0	239.4	CAV	163.6	330.3	CAV
2.5	5	24.2	44.2	52.4	31.2	61.6	76.0	36.5	77.1	100.0	41.6	89.2	134.0	57.3	124.4	188.8
	10	16	33.3	50.2	18.4	40.1	64.8	22.7	47.2	73.6	25.7	84.5	85.5	35.6	73.7	118.3
	15	28.1	55.1	82.5	33.3	70.9	153.8	39.3	83.5	133.2	45.6	95.3	151.7	63.2	130.7	209.0
	20	44.2	128.9	114.9	53.9	110.4	160.5	60.9	128.9	203.1	71.5	149.3	236.6	98.0	205.4	329.2
	25	66.5	116.9	143.5	84.5	163.6	203.8	98.5	198.2	264.5	112.5	229.2	294.1	156.0	316.2	495.7
	30	96.6	149.3	CAV	129.8	211.3	CAV	150.2	273.8	CAV	175.1	354.8	CAV	239.1	498.3	CAV
5	10	13.5	28.6	43.8	15.4	34.4	56.6	19.1	40.5	64.2	21.6	72.5	74.7	29.9	63.2	103.2
	15	25.4	50.5	76.2	30.2	64.9	142.0	35.6	76.4	123.0	41.4	87.3	140.1	57.3	119.7	193.1
	20	41.2	121.2	108.6	50.3	103.7	151.7	56.9	121.2	192.0	66.8	140.4	223.6	91.5	193.1	311.2
	25	63.1	111.5	137.4	80.2	156.0	195.1	93.4	189.0	253.3	106.7	218.5	281.6	148.0	301.5	474.6
	30	92.6	143.6	152.8	124.4	203.2	229.2	143.9	263.4	312.5	167.7	341.3	437.3	229.1	479.4	581.9
7.5	10	10.3	22.9	36.4	11.8	27.6	46.9	14.6	32.5	53.2	16.5	58.1	61.9	22.8	50.7	85.6
	15	22.5	45.4	69.3	26.7	58.3	129.2	31.5	68.7	111.9	36.6	78.4	127.5	50.7	107.6	175.6
	20	38.1	112.9	101.9	46.5	96.7	142.4	52.5	112.9	180.2	61.7	130.8	209.9	84.5	179.9	292.0
	25	59.5	105.8	131.0	75.6	148.0	186.0	88.1	179.3	241.5	100.6	207.3	268.5	139.5	286.0	452.5
10	10	88.4	137.7	147.0	118.7	194.9	220.6	137.4	252.5	300.8	160.1	327.3	420.9	218.7	459.6	560.1
	15	19.1	39.6	61.6	22.7	50.9	115.0	26.8	60.0	99.6	31.1	68.4	113.4	43.1	93.9	156.3
	20	34.6	104.0	94.8	42.3	89.1	132.4	47.8	104.0	167.6	56.1	120.5	195.2	76.9	165.8	271.6
	25	55.6	99.7	124.3	70.7	139.5	176.5	82.4	169.0	229.1	94.1	195.4	254.7	130.5	269.7	429.3
30	83.9	131.6	141.1	112.7	186.1	211.6	130.4	241.2	288.6	152.0	312.6	403.9	207.7	439.0	537.4	

NOTE: Where "CAV" is indicated within the above capacity tables, the water has reached full cavitation, and flow is choked.

TABLE 16
MODEL 8311 - "LP VARIATION"
AIR CAPACITY - SCFH
S.G. = 1.0 T = 60°F F_L = 0.88
All Sizes - Composition Diaphragm Only

Outlet Pressure (psig)	Set Point Pressure (psig)	1-1/2" (DN40) Body			2" (DN50) Body			2-1/2" (DN65) Body			3" (DN80) Body			4" (DN100) Body		
		% Build			% Build			% Build			% Build			% Build		
		10%	20%	30%	10%	20%	30%	10%	20%	30%	10%	20%	30%	10%	20%	30%
ATM	2	9100	14090	14540	11920	19690	21800	13710	25330	29290	15720	32020	40610	21950	44530	54920
	5	9070	15670	17810	11660	21840	25830	13670	27350	33990	15550	31660	45550	21440	44140	64180
	10	4530	9250	13770	5190	11130	17770	6430	13100	20160	7250	23460	23450	10050	20460	32420
	15	7500	14680	21930	8900	18880	40910	10510	22230	35420	12210	25380	40360	16910	34810	55600
	20	11770	34500	30930	14360	29540	43200	16240	34500	54690	19070	39960	63690	26130	54980	88620
	25	18000	31970	39660	22870	44720	56310	26660	54180	73110	30450	62640	81280	42220	86440	136980
2.5	5	8870	15320	17420	11400	21360	25270	13370	26750	33250	15210	30970	44550	20970	43180	62770
	10	4530	9250	13770	5190	11130	17770	6430	13100	20160	7250	23460	23450	10050	20460	32420
	15	7500	14680	21930	8900	18880	40910	10510	22230	35420	12210	25380	40360	16910	34810	55600
	20	11770	34500	30930	14360	29540	43200	16240	34500	54690	19070	39960	63690	26130	54980	88620
	25	18000	31970	39660	22870	44720	56310	26660	54180	73110	30450	62640	81280	42220	86440	136980
	30	26770	41950	45120	35950	59340	67680	41610	76900	92300	48490	99660	129150	66230	139980	171860
5	10	4430	9040	13470	5080	10890	17380	6290	12810	19720	7090	22950	22940	9830	20020	31710
	15	7500	14680	21930	8900	18880	40910	10510	22230	35420	12210	25380	40360	16910	34810	55600
	20	11770	34500	30930	14360	29540	43200	16240	34500	54690	19070	39960	63690	26130	54980	88620
	25	18000	31970	39660	22870	44720	56310	26660	54180	73110	30450	62640	81280	42220	86440	136980
	30	26770	41950	45120	35950	59340	67680	41610	76900	92300	48490	99660	129150	66230	139980	171860
7.5	10	3680	7500	11160	4210	9020	14400	5210	10620	16350	5880	19020	19010	8150	16590	26290
	15	7340	14360	21450	8710	18460	40010	10280	21740	34650	11940	24820	39480	16540	34050	54390
	20	11760	34480	30910	14350	29520	43180	16230	34480	54650	19050	39940	63650	26110	54950	88570
	25	18000	31970	39660	22870	44720	56310	26660	54180	73110	30450	62640	81280	42220	86440	136980
10	10	26770	41950	45120	35950	59340	67680	41610	76900	92300	48490	99660	129150	66230	139980	171860
	15	6680	13070	19530	7930	16810	36420	9350	19790	31540	10870	22590	35930	15050	31000	49510
	20	11510	33750	30260	14040	28890	42260	15890	33750	53490	18650	39090	62300	25560	53780	86680
	25	17960	31890	39560	22820	44620	56180	26600	54060	72940	30380	62500	81090	42120	86240	136660
30	26770	41950	45120	35950	59340	67680	41610	76900	92300	48490	99660	129150	66230	139980	171860	

TABLE 17
MODEL 8311 - "LP VARIATION"
STEAM CAPACITY - LBS/HR
S.G. = Actual T = Saturated F_L = 0.88
All Sizes - Metal Diaphragm

Outlet Pressure (psig)	Set Point Pressure (psig)	1-1/2" (DN40) Body			2" (DN50) Body			2-1/2" (DN65) Body			3" (DN80) Body			4" (DN100) Body		
		% Build			% Build			% Build			% Build			% Build		
		10%	20%	30%	10%	20%	30%	10%	20%	30%	10%	20%	30%	10%	20%	30%
ATM	5	231	411	612	278	536	814	327	623	1020	378	710	1173	517	982	1627
	10	112	216	386	127	259	463	151	290	510	178	336	618	243	463	838
	15	201	393	598	230	479	766	263	551	862	326	632	1005	388	857	1364
	20	343	647	905	399	793	1231	455	928	1434	534	1068	1631	737	1484	2288
	25	528	958	HI VEL	639	1219	HI VEL	756	1434	2346	860	1629	2763	1173	1955	3747
	30	805	HI VEL	HI VEL	975	1853	HI VEL	1145	2156	HI VEL	1322	2474	3456	1809	3389	4800
2.5	5	177	314	468	212	410	622	249	476	780	289	543	896	395	750	1243
	10	104	201	358	118	240	430	140	269	473	165	312	573	226	430	777
	15	195	381	581	223	465	744	256	534	837	316	613	976	376	832	1325
	20	339	640	895	395	784	1218	450	918	1418	528	1057	1613	729	1468	2264
	25	518	941	HI VEL	627	1197	1927	743	1408	2304	845	1600	2714	1152	1920	3681
	30	787	1314	HI VEL	953	1813	HI VEL	1119	2109	2961	1293	2419	3380	1769	3315	4694
5	10	90	175	312	103	209	374	122	234	411	143	271	499	196	374	676
	15	185	361	551	211	441	705	242	507	793	300	581	925	357	788	1255
	20	331	624	874	385	765	1189	440	896	1384	516	1031	1574	711	1433	2209
	25	513	931	1375	621	1185	1907	735	1394	2281	836	1584	2686	1140	1901	3643
	30	782	1305	HI VEL	947	1800	2338	1112	2094	2940	1284	2402	3356	1757	3292	4661
7.5	10	68	131	234	77	157	281	91	176	309	108	204	375	147	281	508
	15	169	330	504	193	403	645	222	463	725	274	532	846	326	721	1148
	20	318	599	839	370	735	1141	422	860	1329	495	990	1511	683	1376	2121
	25	503	912	1347	608	1161	1868	720	1366	2235	819	1552	2632	1117	1862	3569
	30	774	1293	1669	938	1783	2315	1101	2074	2912	1271	2379	3324	1740	3260	4617
10	15	146	284	433	166	347	554	191	399	624	236	457	728	281	620	988
	20	298	562	787	347	689	1071	396	807	1247	464	929	1418	640	1291	1990
	25	487	883	1304	589	1123	1808	697	1322	2163	793	1502	2547	1081	1802	3454
	30	761	1270	1640	921	1752	2275	1082	2038	2861	1249	2338	3266	1710	3203	4536

NOTE: Where "HI VEL" is indicated, the flow has reached or exceeded a velocity of Mach 0.35, an accepted limit for expanded steam on the downstream side. Use of higher velocities normally generate excessive noise levels.

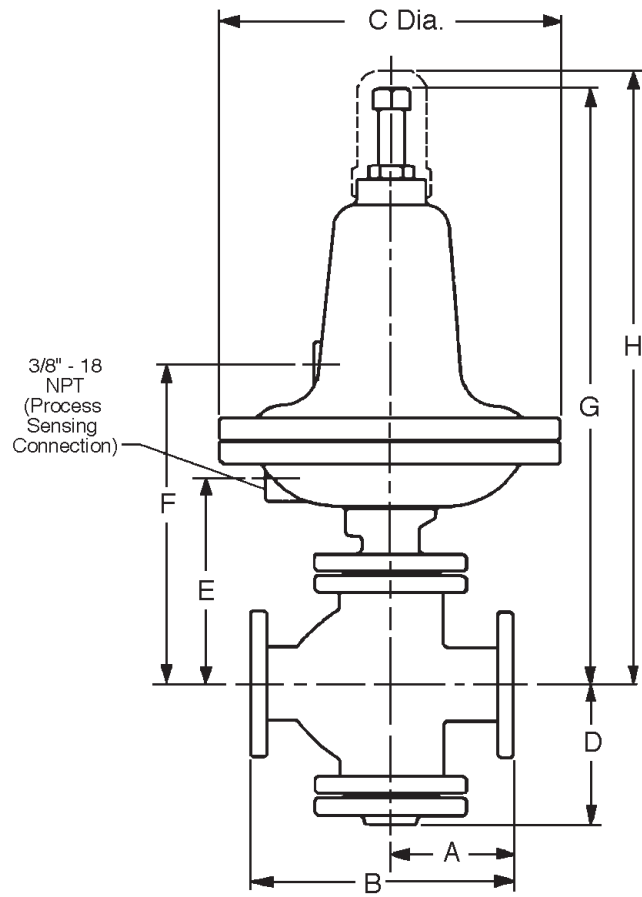

Figure 2: Model 8311LP/HP Dimensional

DIMENSIONS AND WEIGHTS — ENGLISH UNITS

Size Inches	End Connection	Dimensions - Inches									Approximate Ship Weight lbs.	
		A	B	C		D	E	F	G	H	"LP"	"HP"
				"LP"	"HP"							
1-1/2" *	NPT	3.69	8.00	14.00	11.25	4.75	6.89	11.12	20.25	20.50	121	100
	125/150# Flgd.	4.06	8.75								127	106
	250/300# Flgd.	4.31	9.25								135	114
2" **	NPT	4.25	9.26	14.00	11.25	6.38	8.44	12.69	21.50	22.00	161	140
	125/150# Flgd.	4.62	10.00								173	152
	250/300# Flgd.	4.88	10.50								177	156
2-1/2"	125/150# Flgd.	5.06	10.88	14.00	11.25	6.38	8.44	12.69	21.50	22.00	201	180
	250/300# Flgd.	5.38	11.50								206	185
3"	125/150# Flgd.	5.50	11.75	14.00	11.25	7.69	9.74	14.00	22.75	23.50	226	205
	250/300 # Flgd.	5.88	12.50								234	213
4"	125/150# Flgd.	6.56	13.88	14.00	11.25	7.69	9.74	14.00	22.75	23.50	251	230
	250/300# Flgd.	6.88	14.50								269	248

* 1-1/2" Size CS body material with Opt-34: "A" dim. = 7.31" & "B" dim = 14.00"
** 2" Size CS body material with Opt-34: "A" dim. = 7.38" & "B" dim = 14.00"

DIMENSIONS AND WEIGHTS — METRIC UNITS

Size (DN)	End Connection	Dimensions (mm)									Approximate Ship Weight (Kg.)	
		A	B	C		D	E	F	G	H	"LP"	"HP"
				"LP"	"HP"							
(40) *	NPT	94	203	356	286	121	175	283	514	521	54.88	45.35
	125/150# Flgd.	103	222								57.60	48.07
	250/300# Flgd.	110	235								61.23	51.70
(50) **	NPT	108	235	356	286	162	214	322	546	559	73.02	63.49
	125/150# Flgd.	117	254								78.46	58.94
	250/300# Flgd.	124	267								80.27	70.75
(65)	125/150# Flgd.	129	276	356	286	162	214	322	546	559	91.16	81.63
	250/300# Flgd.	137	292								93.42	83.90
(80)	125/150# Flgd.	140	298	356	286	195	247	356	578	597	102.50	92.97
	250/300 # Flgd.	149	318								106.12	96.60
(100)	125/150# Flgd.	167	352	356	286	195	247	356	578	597	113.83	104.31
	250/300# Flgd.	175	368								122.00	112.47

* DN40 Size CS body material with Opt-34: "A" dim. = 185mm & "B" dim = 356mm.
** DN50 Size CS body material with Opt-34: "A" dim. = 187mm & "B" dim = 356mm.

The contents of this publication are presented for informational purposes only, and while every effort has been made to ensure their accuracy, they are not to be construed as warranties or guarantees, express or implied, regarding the products or services described herein or their use or applicability. We reserve the right to modify or improve the designs or specifications of such product at any time without notice.
Cashco does not assume responsibility for the selection, use or maintenance of any product. Responsibility for proper selection, use and maintenance of any Cashco product remains solely with the purchaser.

MODEL 8311 PRODUCT CODER 07/20/21

An "X" in POS 12 followed by a 5-digit control number overrides remaining selections.

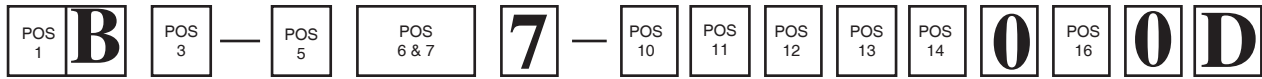

POSITION 1 - VALVE TYPE	
Description	CODE
MODEL "8311HP" Back Pressure Relief Regulator	S
MODEL "8311LP" Back Pressure Relief Regulator	T

POSITION 3 - SIZE				
Available End Connections				
Size		NPT	Flanged	CODE
In	(DN)			
1-1/2"	(40)	YES	YES	8
2"	(50)	YES	YES	9
2-1/2"	(65)	NO	YES	A
3"	(80)	NO	YES	B
4"	(100)	NO	YES	C

POSITION 5 - BODY & SP. CHAMBER MATERIALS	
Body/Sp. Ch.	CODE
CI / * Iron	1
CS/CS	5

* Ductile Iron Sp.Ch. for 8311HP
Cast Iron Sp.Ch. for 8311LP

POSITION 6 & 7 - TRIM	
Desig.	CODE
S1	S1
S5	S5
S40	40
S36	36
S36R	3R
S7	S7
S7R	SR
S3	S3

POSITION 10 - END CONNECTIONS	
Description	CODE
NPT - Screwed	1
-30 Opt. Integral Flanged	
125 LB Flgs CI Only	3
150 LB Flgs CS Only	6
250 LB Flgs CI Only	5
300 LB Flgs CS Only	7
-34 Opt. - 150 LB RF Flgs. 14" F to F Dimension (Sizes 1-1/2" & 2" only) *	V
-34 Opt. - 300 LB RF Flgs. 14" F to F Dimension (Sizes 1-1/2" & 2" only) *	W

* CS body material only. Nipples & flanges of same material as body.

POSITION 11 - RANGE SPRING			
Product	Range		CODE
	psig	(Barg)	
8311HP	10-40	(.69-2.8)	1
	30-100	(2.1-6.9)	8
	75-145	(5.2-10.0)	9
	130-200 *	(9.0-13.8)	B
8311LP	1-4 √	(.07-.28)	5
	3-10	(.21-.69)	6
	8-30	(.55-2.1)	7

* Includes Opt-80 for High Inlet Pressure construction.
√ Comp diaphragm only.

POSITION 12 - TRIM VARIATIONS		
Description	Option	CODE
No Special Trim Variation.	--	0
Stellited Seat Surface - S1 and S5 Trim Only.	-15	A
For Special Construction Contact Cashco for Special Product Code.	SPQ	X

POSITION 14 - SPRING CHAMBER OPTIONS		
Description	Option	CODE
No Option	-	0
1/4" NPT Vent Tap.	-25	E
Plastic Rain-proof Bug Vent (includes Opt-25).	-25P	P
SST Rain-proof Bug Vent (includes Opt-25).	-25S	H

POSITION 13 - FEATURE OPTIONS		
Description	Option	CODE
No Option	-	0
Closing Cap	-1	1

POSITION 16 - CERTIFICATE OPTIONS		
Description	Option	CODE
No Option	-	0
Special Cleaning: Per Cashco Spec #S-1542.	-56	N

*** For information on ATEX see pages 8 & 9 on the IOM.**

Cashco
P.O. Box 6
Ellsworth, KS 67439-0006
PH (785) 472-4461
Fax. # (785) 472-3539
www.cashco.com
email: sales@cashco.com
Printed in U.S.A. 8311-TB

Cashco GmbH
Handwerkerstrasse 15
15366 Hoppegarten, Germany
PH +49 3342 30968 0
Fax. No. +49 3342 30968 29
www.cashco.com
email: germany@cashco.com

Cashco do Brasil, Ltda.
Al.Venus, 340
Indaiatuba - Sao Paulo, Brazil
PH +55 11 99677 7177
Fax. No.
www.cashco.com
email: brazil@cashco.com